



# Wireless without worries.





### **WHY LUMENRADIO?**

LumenRadio was founded with a clear vision of how wireless technology will change the world. We have been leading the wireless transformation within the lighting industry by consistently being the first to introduce new groundbreaking technology.

### **RELIABILITY**

LumenRadio's reliability comes from developing products with feature sets that assure successful operation even in worst-case environments. Our products are designed to withstand daily wear and tear in harsh environments and our manufacturing and testing processes makes sure that the products we ship always fulfill the most rigorous requirements. We ship all our products with pride and all units proudly carry the "Made in Sweden" mark.

### **SUPPORT**

We are dedicated to building a world-class support team who assist our customers when needed. Customers all around the world use our products for challenging concerts and live projects, permanent archtainment installations and projects in extreme outdoor environments. When in need of assistance or recommendations, we are always glad to help.

### **TECHNOLOGY**

We believe in pleasantly surprising our customers with new innovations and groundbreaking technology. Our technology has between 2009 and 2016 won more awards for technical achievements and excellence than any competitor in our market segment.

If you are a newcomer to our wireless technology or an old devotee, you are equally welcome to enjoy the technology our team has developed with passion, love and fanatical attention to perfection.

---

### **SALES**

[sales@lumenradio.com](mailto:sales@lumenradio.com)

### **MARKETING**

[marketing@lumenradio.com](mailto:marketing@lumenradio.com)

### **SUPPORT**

[support@lumenradio.com](mailto:support@lumenradio.com)



Our offer can be summed up in three words: *Wireless without worries*. With our turnkey solutions, comprehensive experience and radio expertise, we enable you to focus on creating amazing solutions without having to worry about how connectivity actually works. Let us show you how.

## Contents

How to be wireless . . . . .	4
Indoor entertainment . . . . .	6
Permanent installations . . . . .	10
Extreme outdoor . . . . .	12
OEM solutions . . . . .	14
OEM partners . . . . .	20
Implementation guide. . . . .	23
Management software. . . . .	24
Accessories . . . . .	26
Distributors . . . . .	28
Specifications . . . . .	30
Contact. . . . .	36



## 4 time winner...

1. PLASA GOLD AWARD FOR INNOVATION 2014 | *For the CRMXchip*
2. PLASA AWARD FOR INNOVATION 2013 | *For the SuperNova3 software*
3. PLASA AWARD FOR INNOVATION 2010 | *For the CRMX Nova Flex unit*
4. PLASA AWARD FOR INNOVATION 2009 | *For the CRMX Nova Product range*

# How to be wireless?

Whether your installation demands wireless for cosmetic, cost saving or technical reasons, there are a few factors you should be aware of to ensure optimum performance of a wireless system. LumenRadio has a team of dedicated wireless experts available to guide you through your installation, but here are a few pointers to get you started:

## WHAT RANGE CAN I EXPECT FROM MY WIRELESS SYSTEM?

The quick answer is "up to 1000 meters with line of sight". The longer answer is that wireless signals can be transmitted over vast distances, into tens of kilometers - it's simply a question of correct selection of antennas and repeaters. Likewise, materials placed 'in the way' of the wireless link, such as walls, windows, trees and people, all cause a reduction in signal strength of the wireless link. With the correct selection of antennas, use of repeaters and some forethought, a reliable wireless link can be delivered in even the most challenging scenarios.

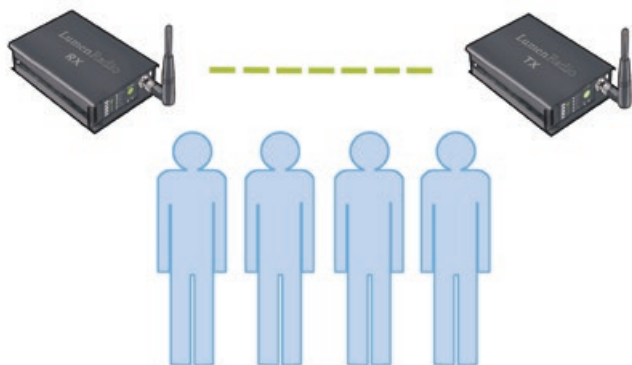

## WHERE SHOULD I PLACE MY WIRELESS UNITS?

The key to avoiding most common obstacles is to place transmitters and receivers as high as possible. One example is an audience, which consists of 75% water (which absorbs radio waves). By placing your transmitters and receivers above an audience's head, you can dramatically improve signal strength and reliability.

## WHICH ANTENNA SHOULD I USE?

All CRMX products ship with a 2dBi antenna as standard. Although this is suitable for over 95% of applications, a range of higher gain and directional antennas is available for those applications which are particularly challenging. It is preferable to fit the higher gain antenna to the receiver, as this provides optimum signal strength without increasing signal transmission power, which is often controlled by regulations to a maximum level.

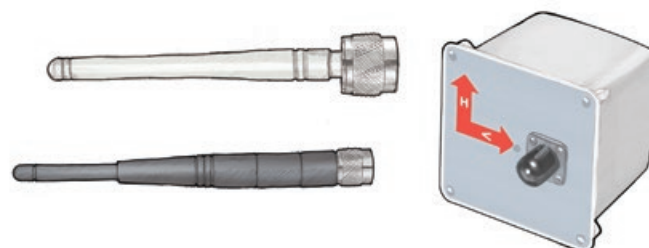



## HOW DO I CHOOSE WHICH PRODUCT TO USE?

LumenRadio offer a range of products to suit your installation - indoor Nova units are suitable for use on temporary events, as rental stock or for other indoor applications. The durable Slim units are perfect for permanent installation both in- and outdoors, whilst the Outdoor units offer industry leading IP67 classification for vandal and weather protection. Whatever the environment, LumenRadio have a product to meet your requirements.

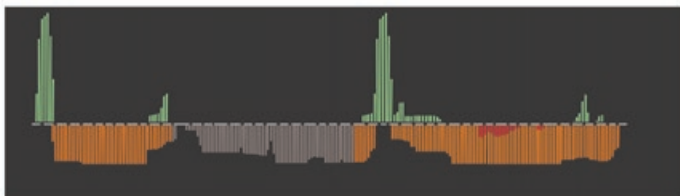

## WHAT IS COEXISTENCE?

LumenRadio's patented Cognitive Coexistence technology allows our radio to ensure optimum performance even when other wireless systems are operating in the same area.

As the world becomes more and more wireless; systems such as Wi-Fi, ZigBee, Bluetooth, wireless microphones, wireless cameras, smart phones and even microwave ovens all occupy the same wireless frequency range. This frequency range is often congested and this can affect the performance of all these systems, with radio systems transmitting on top of one another or cancelling each other out.

CRMX enabled products continuously scan the wireless frequencies, detecting activity from other networks and where gaps are available. The radio modules then 'hop' into these available frequencies, making best use of the available space whilst reducing the effects on other networks to almost zero.

## WIRELESS IS AS EASY AS 1, 2, 3 ...

- 1.** Unlink all receivers by pushing and holding the link button until the LEDs turn off.
- 2.** Push the link button on the transmitter... The transmitter will automatically link to all receivers within range and immediately start sending DMX data to them.
- 3. Job done!** Relax, knowing your wireless link is being managed by CRMX technology.



# INDOOR ENTERTAINMENT

## CRMX Nova

**The CRMX Nova range is designed to meet the requirements of entertainment lighting; to withstand the wear and tear of touring, rental and stage use.**

**CRMX Nova has received PLASA's Award for Innovation twice. Both for the superior engineering in developing the CRMX Nova product line and for CRMX Nova Flex's ability to act as a complete cross-protocol wireless lighting control system.**

CRMX Nova is available as a DMX product, or with optional RDM functionality. All units operate on the 2.4 GHz band, and can be used around the globe without a license. All products feature the fundamental CRMX features such as Automated Cognitive Coexistence, DMX synchronization, lowest latency in the industry at 5 ms, strong 128 bit encryption, up to 1000 meter link range, error correction and fidelity. CRMX Nova receivers are also compatible with W-DMX™ transmitters.

The CRMX Nova RDM products can be used with SuperNova software. RDM transmitters and Flex products can also be used as RDM proxy devices, alongside any RDM controller. In addition to this; all CRMX Nova RDM products have support for wired and wireless in the same installation.





## CRMX NOVA FX RDM

### RDM/ETHERNET FLEX PRODUCT

CRMX Nova FX RDM can be configured either as a transmitter or a receiver for one full DMX/RDM universe of up to 512 channels, making it ideal for rental applications. In transmitter mode, all supported Ethernet protocols can be used in any direction, both as input and output. In receiver mode, it can output any supported Ethernet protocol alongside standard DMX and RDM. CRMX Nova FX RDM supports both wired and wireless RDM.

#### KEY FEATURES

- Single Universe Flex unit
  - Transmitter or Receiver
- DMX512-A and RDM support
- Ethernet or wired DMX input/output
- Compatible with W-DMX™ transmitters
- Up to 1000 meter link range
- Connects to SuperNova
- 5 ms latency
- 128 bit encryption of wireless link
- Automated Cognitive Coexistence
- Forward Error Correction
- RP-TNC antenna connector



## CRMX NOVA TX2 RDM

### RDM/ETHERNET TRANSMITTER

CRMX Nova TX2 RDM is a dual universe RDM enabled transmitter. Input can be provided by XLR or Ethernet inputs. CRMX Nova TX2 RDM supports both wired and wireless RDM.

#### KEY FEATURES

- Dual Universe Transmitter
- DMX512-A and RDM support
- Ethernet or wired DMX input
- Up to 1000 meter link range
- Connects to SuperNova
- 5 ms latency
- 128 bit encryption of wireless link
- Automated Cognitive Coexistence
- Forward Error Correction
- RP-TNC antenna connector



## CRMX NOVA RX RDM

### RDM RECEIVER

CRMX Nova RX RDM is a single universe RDM enabled receiver. It has support for one full DMX/RDM universe of up to 512 channels being transmitted by a CRMX transmitter. Connect a CRMX Nova RX RDM to any RDM enabled fixture to get wireless feedback from the fixture.

#### KEY FEATURES

- Single Universe Receiver
- DMX512-A and RDM support
- Compatible with W-DMX™ transmitters
- Up to 1000 meter link range
- Connects to SuperNova
- 5 ms latency
- 128 bit encryption of wireless link
- Automated Cognitive Coexistence
- Forward Error Correction
- RP-TNC antenna connector



## CRMX NOVA TX DMX TRANSMITTER

Our entry level indoor transmitter. The CRMX Nova TX has support for one full DMX universe of up to 512 channels.

### KEY FEATURES

- Single Universe Transmitter
- Support for DMX512-A
- Up to 1000 meter link range
- 5 ms latency
- 128 bit encryption of wireless link
- Automated Cognitive Coexistence
- Forward Error Correction
- RP-TNC antenna connector



## CRMX NOVA RX DMX RECEIVER

Our entry level indoor receiver. The CRMX Nova RX has support for one full DMX/RDM universe of up to 512 channels being transmitted by a CRMX transmitter.

### KEY FEATURES

- Single Universe Receiver
- Support for DMX512-A
- Compatible with W-DMX™ transmitters
- Up to 1000 meter link range
- 5 ms latency
- 128 bit encryption of wireless link
- Automated Cognitive Coexistence
- Forward Error Correction
- RP-TNC antenna connector



## CRMX NOVA TX USB DMX TRANSMITTER

The CRMX Nova TX USB delivers never before seen accessibility to the powerful CRMX technology. With its small size and easy to use USB interface it is suitable for small to medium sized temporary shows and works in perfect combination with battery powered fixtures with built-in CRMX technology. This unique product offers all of the advanced features of the larger CRMX Nova products but in a smaller enclosure; Automated Cognitive Coexistence, DMX fidelity and error correction, lowest latency in the industry at 5ms and 128 bit encryption - it's all there.

### KEY FEATURES

- Single Universe Transmitter
- USB type A connector
- Supports ENTTEC DMX USB protocol
- Up to 200 meter link range
- Internal antenna
- 5 ms latency
- 128 bit encryption of wireless link
- Automated Cognitive Coexistence
- Forward Error Correction





# TUPAC MARTIR'S groundbreaking opera Nierka

*"Since technology was an essential part of the performance, we created a scene in which the characters on stage lit up the space with LEDs that had been embedded in the costumes"*

- Tupac Martir, Creative Director

He has been called "light magician" by Tony Chambers, Editor of Wallpaper magazine, and worked with major organizations and significant artists such as Alexander McQueen, Vivienne Westwood, Stella McCartney, Louis Vuitton, Elton John, Beyonce and Sting. When the light magician, Tupac Martir, together with Panalux were working on the presentation for the new groundbreaking presentation of Nierka, in the Peacock Theatre in London, they decided to once again go wireless with LumenRadio's CRMX products.

All LEDs as well as the LumenRadio CRMX receivers were powered by batteries, which were placed in the costumes so that the musicians would have the freedom to move around the stage. Martir's idea of dancing light, in which the audience watches lights dance instead of the performers, was essential to the story. Martir adds "By giving individual IDs to each one of the musicians, Associate LD Muly Yechezkel was able to give the musicians more dynamism. We were able to wirelessly change the color of the LEDs as the different

parts played new chords, while in the same time dimming the band at the back on the stage for their light to travel across the stage and creating a backlight for the dancers". One of the major challenges and one of the poignant moments of the show was the dress created by Martir and costume design associate Gabriela Gower. The dress that measures 8 x 13 meters and weights 150kg was a major focus for Martir, since it was one of the earliest concept drawings. Due to the movement of the soprano, two LumenRadio CRMX receivers were placed in the back of the costume in order to control the left and right side of the dress, giving the flexibility to the creative team to play with intensities, color and dimming across it.

Martir's fantastic storytelling and LumenRadio's wireless CRMX products are proof that trustworthy wireless equipment enables outstanding flexibility and creativity on stage that is needed in an ever-changing spectrum of performance.

# PERMANENT INSTALLATIONS



## CRMX Slim

**CRMX Slim is a compact and cost efficient wireless unit rated for permanent indoor and outdoor installations. CRMX Slim products can easily be mounted inside lighting poles or anywhere else where space is limited. The integrated DMX to DALI converter makes it a perfect solution where DMX and DALI fixtures are mixed in the same installation.**

All CRMX Slim products are IP65 rated and have a discreet and secure housing, which ensures reliable long-term operation in outdoor or other humid environments. All connections are made via two cable glands. The glands offer full environmental protection up to IP65. CRMX Slim products have been used in hundreds of permanent indoor and outdoor installations all over the world.



### CRMX SLIM RX RDM

IP65 RDM RECEIVER WITH DALI

CRMX Slim RX RDM supports not only a full 512 channel universe of DMX and RDM, but also DALI and DSI.

The integrated DMX to DALI/DSI converter supports up to 64 DALI addresses or 16 DALI groups as well as DALI or DSI broadcast. It is easily configured over RDM or from SuperNova.



### CRMX SLIM TX

IP65 DMX TRANSMITTER

Our entry level outdoor transmitter. The CRMX Slim TX supports one full DMX universe of up to 512 channels.

#### KEY FEATURES

- Single Universe Receiver
- DMX512-A and RDM support
- Compatible with W-DMX™ transmitters
- Up to 1000 meter link range
- Connects to SuperNova
- 5 ms latency
- 128 bit encryption of wireless link
- Automated Cognitive Coexistence
- Forward Error Correction
- IP65 classification
- N-type antenna connector
- Integrated DMX to DALI/DSI bridge

#### KEY FEATURES

- Single Universe Transmitter
- Support for DMX512-A
- Up to 1000 meter link range
- 5 ms latency
- 128 bit encryption of wireless link
- Automated Cognitive Coexistence
- Forward Error Correction
- IP65 classification
- N-type antenna connector

## CASE STUDY

*“Having used LumenRadio’s Slim units in sub-freezing temperatures many times before, we knew we would be able to deliver both the functionality and reliability necessary.”*

# Lux Helsinki

Photo: Hannu Iso-Oja

**At the annual Lux Helsinki festival, we once again proved that arctic conditions is not a problem for LumenRadios sturdy products. A number of CRMX Slim units were used to realise the vision of Light Artist Kari Kola with his piece Color Park.**

In Color Park the audience can switch the color of the illuminated details of the artwork through several interactive movement and distance sensors. Kola urges the viewers to play with his art: “You can step under a coloured light and your presence will tone the vault next to the Old Church. Ask your friend to come along and you can mix the colours together” explains Kola on his piece. “Or try painting with your hand! Colors react to the sound frequency of the theremin, an instrument invented nearly a hundred years ago. The changes in the sound frequency changes the frequency of light, in other words, the color of light”, hints Kola on his new experiment.

Kola’s signature shows in strong colours that play the main role in the artwork. This results in tranquil, nearly a meditative vibe in the park in which the viewers can focus on experiencing and exploring light. The visuality of the artwork is supported by multi-channel soundscape. Color Park will be one of Kola’s largest pieces of light art in Finland.

LumenRadio’s Finnish distributor Sun Effects were tasked with providing the wireless infrastructure necessary for the installation. In total 6 x CRMX Slim TX and 20 x CRMX Slim RX RDM were used to reliably distribute data to remote locations.

Otso Vartiainen, Lighting & System Designer at Sun Effects explains: “An installation of this size and type would be very difficult to pull off using DMX cables. Having used LumenRadio’s Slim units in sub-freezing temperatures many times before, we knew we would be able to deliver both the functionality and reliability necessary.”

LumenRadio’s CRMX Slim series is the most compact and cost efficient wireless unit for permanent indoor and outdoor installations. CRMX Slim products can easily be mounted inside lighting poles or anywhere else where space is limited. The integrated DMX to DALI converter makes it a perfect solution where DMX and DALI fixtures are mixed in the same installation. All CRMX Slim products are IP65 rated and have a discreet and secure housing which ensures reliable long-term operation in outdoor or other humid environments.

# EXTREME OUTDOOR

## CRMX Outdoor

**CRMX Outdoor is an adaptation of the CRMX Nova product line for outdoor use with the same advanced CRMX technology and features for wireless DMX and RDM distribution.**

With its discreet and secure metal housing and integrated shock absorption, CRMX Outdoor is built to withstand any outdoor environment for many years. Since all CRMX Outdoor products are IP67 rated, they are

not only safe to install in humid environments, but will even withstand temporary submersion. Power and DMX inputs are made via cable glands at the bottom of the main enclosure. The Flex unit also supports Power over Ethernet as an alternative to a mains power input. With support for the most common Ethernet protocols, only one cable is needed for power and control.



### CRMX OUTDOOR FLEX IP67 RDM/ETHERNET FLEX PRODUCT

CRMX Outdoor Flex can be configured either as a transmitter, receiver or repeater for one full DMX/RDM universe of up to 512 channels. In transmitter mode, all supported Ethernet protocols can be used as both input and output. In receiver mode, it can output any supported Ethernet protocol alongside standard DMX and RDM. As a repeater, the Outdoor Flex can be used to build advanced network infrastructures over long distances while also acting as a receiver. The Outdoor Flex supports both wired and wireless RDM.

#### KEY FEATURES

- Single Universe Flex unit - Transmitter, Receiver or Repeater
- DMX512-A and RDM support
- Power over Ethernet support
- Ethernet or wired DMX input/output
- Compatible with W-DMX™ transmitters
- Up to 1000 meter link range
- Connects to SuperNova
- 5 ms latency
- 128 bit encryption of wireless link
- Automated Cognitive Coexistence
- Forward Error Correction
- IP67 classification
- N-type antenna connector
- Vandal proof casing



### CRMX OUTDOOR RX IP67 RDM RECEIVER

CRMX Outdoor RX is an outdoor receiver for one full DMX/RDM universe of up to 512 channels being transmitted by a CRMX transmitter.

#### KEY FEATURES

- Single Universe Receiver
- DMX512-A and RDM support
- Compatible with W-DMX™ transmitters
- Up to 1000 meter link range
- Connects to SuperNova
- 5 ms latency
- 128 bit encryption of wireless link
- Automated Cognitive Coexistence
- Forward Error Correction
- IP67 classification
- N-type antenna connector
- Vandal proof casing

# Stunning Eventim Apollo

*"GDS recognizes that the combination of reliable wireless, RDM feedback and top quality support offered by LumenRadio is of the highest order and consequently they were the obvious choice for this project"*

*- Matt Lloyd, GDS*

**There is perhaps one venue whose name is carved deeper than any other in the hearts of every self-respecting British music fan. Opened in 1932 and designed by Robert Cromie in Art Deco style as The Gaumont Palace cinema, it was renamed the Hammersmith Odeon in 1962, later the Hammersmith Apollo and now after an extensive refurbishment that has restored it to its former Art Deco glory, it will be known as the Eventim Apollo.**

GDS was invited to join the design team tasked with the restoration. The vision was to work within the fabric of the original 1932 Robert Cromie masterpiece and wherever possible restore the historical fixtures.

The installation used a whole DMX universe that exceeded the normal ARC system 64 channel capability. LumenRadio were glad to help by providing an integrated CRMX OEM solution that connected perfectly with the ARC system electronics. Of critical importance to any refurbishment solution is the need for work to progress quickly

and the Apollo was no exception. The work was completed in a nine week turnaround and delivered a complete transformation of the whole space. GDS chose LumenRadio's CRMX technology on this prestigious project because it was essential to deliver a large number of DMX channels to certain fixtures which could not be cabled. Frame integrity as well as flawless data transfer was an absolute requirement for Eventim Apollo and this is one of the many performance areas where CRMX really excels.

GDS Managing Director Matt Lloyd underlined the value of GDS' existing relationship with LumenRadio:

"We have worked closely for a number of years with LumenRadio on some of our wireless product ranges. GDS recognizes that the combination of reliable wireless, RDM feedback and top quality support offered by LumenRadio is of the highest order and consequently they were the obvious choice for this project."



# OEM SOLUTIONS

## CRMX OEM solutions

**LumenRadio's CRMX OEM range allow manufactures to easily integrate all the advantages of the CRMX technology into their products. Fixtures, controllers and other devices with CRMX OEM technology integrated will be fully compatible with other CRMX products.**

Products equipped with the RDM enabled CRMX OEM classic or CRMX TiMo are also compatible with SuperNova and third party RDM controllers which allows for easy visualization, configuration and monitoring. The CRMX technology is the fastest growing wireless lighting system in the industry and some of the largest and most respected lighting companies in the world are going wireless with CRMX. LumenRadio provide full integration support to prospective OEM clients, and are able to advise on all aspects of going wireless - from antenna placement to software interfaces.

The LumenRadio OEM range contains of a wide variety of OEM options:

**CRMX OEM classic** - our standard plug-in modules where we offer a choice of DMX only versions or options that feature RDM.

**CRMXchip** - the world's smallest wireless DMX receiver. Measuring only 6 x 6mm, CRMXchip has quickly become a standard feature in many manufacturer's product lines.

**CRMX TiMo** - the newest addition to the CRMX OEM family, is a smaller, cheaper and updated version of our CRMX OEM classic. CRMX TiMo is the smallest fully integrated wireless RDM receiver on the planet and represents the next generation CRMX technology.

# CRMX OEM classic



Available as  
DMX Receiver  
DMX Transmitter  
DMX Flex

## CRMX OEM DMX

CRMX OEM DMX is the OEM version of the CRMX Nova DMX products. It supports one full DMX universe of up to 512 channels at maximum refresh rate. It is available as a DMX receiver, DMX transmitter or DMX transceiver with Flex functionality that can act either as a receiver or as a transmitter, allowing the user to switch between modes on demand.

The CRMX OEM DMX is based on LumenRadio's advanced CRMX technology, hence you get all the advanced features such as Automated Cognitive Coexistence, DMX fidelity, low latency, strong encryption, etc, all packed together on one small module. To fit in to legacy wireless systems, the CRMX OEM DMX is compatible with W-DMX™ transmitters.

### KEY FEATURES

- Support for DMX512-A
- Compatible with W-DMX™ transmitters
- Up to 1000 meter link range
- 5 ms latency
- 128 bit encryption of wireless link
- Automated Cognitive Coexistence
- Forward Error Correction
- MCX antenna connector



Available as  
RDM Receiver  
RDM Transmitter

## CRMX OEM RDM

CRMX OEM RDM is the OEM version of the CRMX Nova RDM products. It supports one full DMX universe of up to 512 channels at maximum refresh rate. It is available as a standard DMX/RDM receiver or as a DMX/RDM transmitter on special request.

The CRMX OEM RDM is based on LumenRadio's advanced CRMX technology; hence you get all the advanced features such as automated cognitive coexistence, DMX fidelity, low latency, strong encryption etc. CRMX OEM RDM allows for feedback in RDM enabled fixtures as well as feedback from the module itself, when used together with RDM compatible CRMX Nova and CRMX Outdoor equipment. To fit in to legacy wireless systems, the CRMX OEM RDM receiver is compatible with W-DMX™ transmitters.

### KEY FEATURES

- DMX512-A and RDM support
- Compatible with W-DMX™ transmitters
- Up to 1000 meter link range
- Connects to SuperNova
- 5 ms latency
- 128 bit encryption of wireless link
- Automated Cognitive Coexistence
- Forward Error Correction
- MCX antenna connector

# CRMXchip

The world's smallest wireless DMX receiver

Available exclusively from LumenRadio, the patent pending CRMXchip 24DMX512 is the worlds smallest wireless lighting control solution. Built on the latest chip technologies, CRMXchip includes everything needed for manufacturers to add a multi functional wireless DMX receiver into high volume products.



2004  
W-DMX™

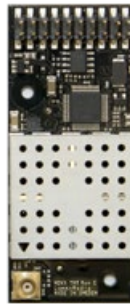

2009  
CRMX



2014  
CRMXCHIP

Building on years of experience in manufacturing industry leading wireless integration modules, LumenRadio's patent pending CRMXchip is an industry first - a compact, developer friendly chip which can be integrated into products with ease. Interfaces are provided for SPI, TTL and (via external drivers) RS485 signals, including an industry first "DMX Window" functionality, which removes the need to process a full 512 slot to locate start addresses within a product. This innovation enables extremely low cost wireless-only products to be manufactured with almost no DMX processing requirements.

CRMXchip can receive signals from all CRMX compatible transmitters, as well as W-DMX transmitters G2, G3, G4 and G4S. A full development kit is available together with advanced development support from LumenRadio engineers; including mechanical, electrical and software development support where required.

With wireless integration available as an on-chip solution, the question is: **what are you waiting for?**

## KEY FEATURES

- QFN48 6mm x 6mm package
- SPI DMX window functionality
- Over the air upgrades of radio drivers
- <40mA current consumption
- Supports receiving CRMX, W-DMX G2, W-DMX G3, W-DMX G4 and W-DMX G4S

## DMX WINDOW

This unique, patent pending, feature allows fixture manufacturers to specify a range of the DMX universe they are interested in. CRMXchip then sends an interrupt when there is a change within this range and makes available only the specified channels via an SPI register. A fixture manufacturer can implement full DMX control by simply reading the relevant data only when the interrupt is received.





# CRMX TiMo

## The world's smallest wireless RDM transceiver

By using the award-winning CRMXchip technology, LumenRadio can offer the only fully integrated DMX/RDM compatible SMT module for high-volume product integration. TiMo is small on form factor but huge on functionality - featuring all of the same capabilities as our full sized CRMX OEM classic modules in a package just 33.5mm x 18.5mm, but with added benefits from CRMXchip such as over-the-air firmware upgrades, SMT mounting and an integrated on-chip antenna as well as a U.FL connector for external antenna.



TiMo is fully compliant with the ETSI EN 300328 (v1.8.1) '2015' revision, as well as fully FCC certified with a modular approval to 300mW - the highest allowed output power of any manufacturer within the industry due to LumenRadio's unique CRMX technology.

As with all LumenRadio receivers, TiMo is fully compatible with all existing CRMX transmitters, as well as transmitters from Wireless Solution running in G2, G3, G4 or G4S 2.4GHz mode, enabling a single wireless component to maximize compatibility within fixtures. Manufacturers can add TiMo to their products easily with full OrCAD, Allegro and DXF symbol libraries available to simply drop onto existing layouts.

Available in two different versions offering receiver or transceiver capabilities, TiMo can be used in many different applications to create new and amazing products.

*CRMX TiMo is available in two different configurations:*

### TiMo RX RDM

TiMo RX RDM is a DMX/RDM receiver for one full DMX universe of up to 512 channels at maximum refresh rate. TiMo RX RDM is fully RDM compatible to allow for remote configuration and monitoring of supported fixtures when used together with RDM compatible CRMX equipment.

### TiMo FX RDM

TiMo FX RDM is a DMX/RDM receiver and a DMX transmitter for one full DMX universe on the same PCB. Mode of operation can be easily changed at any time. In transmitter mode, TiMo FX RDM is a fully operational CRMX transmitter, utilizing our award-winning Cognitive Coexistence technology to minimize interference. In receiver mode, TiMo FX RDM offers the same functionality as TiMo RX RDM.

### DEVELOPMENT KIT

A full development kit is available together with advanced development support from LumenRadio engineers; including mechanical, electrical and software development support where required.

### KEY FEATURES

- Over the air firmware upgrades
- RDM UID binding for transparent RDM capabilities with SuperNova
- Integrated chip antenna for tiny form factor wireless integration
- External RF connectivity via U.FL/IPEX connector

### BINDING UID

Manufacturers are able to set TiMo up with a binding UID which links TiMo to their fixtures RDM UID. This means that controller software, such as SuperNova, can display the fixture as a single entity with the wireless features tightly integrated into the RDM controls of the fixture itself. No other wireless module offers such tight integration into fixture designs.

### FCC MODULAR APPROVAL

TiMo features FCC modular approval under FCC part 15, meaning that manufacturers integrating TiMo into their fixture design are not required to perform additional FCC certification upon adding the component. This saves both time and money in the product development cycle.



# Götaplatsen Gothenburg

## INSTALLATION COST CALCULATION WIRED VS WIRELESS

---

<b>Installation cost wired:</b>	<b>€40,711</b>
Work:	€38,166
Equipment:	€2,545

---

<b>Installation cost wireless:</b>	<b>€4,940</b>
Work:	€635
Equipment:	€4,305

---

**Cost saving with wireless: 87.8%**

**Götaplatsen is a major plaza and focal point for cultural activities in the city of Gothenburg as well as home to a large LumenRadio CRMX system. Götaplatsen is lined by 3 major institutions; the Gothenburg City Theater, the City Art Museum, and the Gothenburg Concert Hall.**

It also features an impressive fountain with a gigantic statue of Poseidon and attracts large crowds for many big annual events. The area was renovated recently with particular emphasis on

improved and coordinated illumination as a part of a citywide plan to enhance the visual environment in major public spaces.

LumenRadio's wireless CRMX technology was deployed to extend the reach of DMX and RDM distribution to all parts of the comprehensive lighting system on and around the plaza without any disruptive and costly construction work. The roof of the City Art Museum does duty as the central transmitter site and IP65 rated CRMX Slim receivers are strategically placed around the plaza to avoid any cabling between



buildings, lighting poles, and fixtures. This allowed the team of designers; Lars Fredén, Iben Winther Orton, Vladan Paunovic, Linda Fagerström, and Eric Eliasson at Ramböll Sverige AB, to maintain an uncluttered appearance and to keep the technical infrastructure invisible to the largest extent possible.

The extensive lighting system is monitored using LumenRadio's SuperNova software; which allows continuous monitoring of all connected devices and fixtures and keeps maintenance personnel

informed about such vital information as signal strength & condition, critical temperatures, errors, and other operational issues.

Götaplatsen was awarded the prestigious 2012 Swedish Lighting Award, which aims to highlight projects where lighting has been used in an exemplary and innovative manner.

# OEM partners

LumenRadio collaborates and have ongoing joint development projects with many industry leading manufacturers. The CRMX technology integrates easily into new and existing products and provides OEM's with wireless connectivity featuring unparalleled DMX and RDM performance. Below are some representative manufacturers and products featuring CRMX technology. It's simply: *Wireless integration without worries.*



**ROBE®**

## Robe Pointe®

This new technology fixture cover the needs of any end user, as the Pointe® is a Beam, Spot, Wash and FX all in one. Pointe® is very bright and super-fast with a sharp parallel beam that cuts through the air and across video with ease. It can project a static or rotating glass gobo to produce precision in-air and surface images with an even focal plane. Tight or at full 20 degree zoom, the output is crystal clear and brilliant. Add in either rotating, 6 way linear or 8 way circular, prisms to create wide reaching effects across any set. This extremely popular fixture features a wireless connectivity option with LumenRadio's award winning CRMX DMX/RDM OEM products inside.



**RJ**  
ROBERT JULIAT

## Robert Juliat Tibo 535

The Tibo LED Fresnel is an innovative energy-efficient part of the Robert Juliat Tibo range. This fixture can be put to good use as back light, side light and wash light in film, TV and studio settings as well as conventional theatre.

Tibo LED is available with the most reliable wireless technology on the market, CRMX!



## JOSEF VALCHAR

FOUNDER AND GENERAL MANAGER AT ROBE LIGHTING

*"Robe chose to partner with LumenRadio because we wanted a wireless partner we could trust. LumenRadio's advanced RDM implementations together with comprehensive support and great people meant they were the obvious choice, and our customers love the integration of the wireless modules into our fixtures".*

**AYRTON**  
Light in action

**ROBE®**

**SGM®**

**KINO FLO®**  
Lighting Systems

**LITEGEAR®**

**ASTERA**

**INNOVATIVE DIMMERS**

**TERBY**  
Terby Professional Light

**RJ**  
ROBERT JULIAT

**tableart**  
the centre of attention

**dblux®**

**CLAY PAKY**

**ProPlex®**

## Astera AX3 Lightdrop™

The AX3 Lightdrop™ is the most advanced LED spotlight for event/DJ lighting. It is the most compact, wireless spotlight on the market and can be attached to a variety of surfaces (ceilings, rails, truss structures etc.) or simply placed inside Astera's decorative polyethylene objects.

The Lightdrop™ is a wireless puck spotlight with a magnetic underside so it can be attached to walls or under tables. It is IP65 rated and equipped with LumenRadio's CRMXchip as standard. The Lightdrop™ has achieved 100% color consistency from one batch to the next, and can hit exact color temperatures and reproduce any LEE filter. The dynamic power-boost feature makes the light able to display the maximum brightness at all times and intensify non-white colors.



## Kino Flo DMX Select 30 and Select 20

Kino Flo Lighting Systems's new DMX Select 30 and Select 20 LED's feature tunable Kelvin, from 2700K to 6500K, with full green to magenta correction, and wireless DMX. From software to hardware, the Select LED lighting systems are re-shaping the future of cinema and television production with lustrous white light that doesn't flicker or shift color temperature when dimmed.

The Select 30 and Select 20 systems can be operated wirelessly, with the use of a LumenRadio transmitter, as an alternative to DMX cables. Kino Flo has further refined the Selects with variable green-magenta settings. Hues can be balanced to other lights on the set and tuned to match the spectral curves of professional digital cameras.

## Ayrton NandoBeam-S9

The NandoBeam S9 luminaire is the latest development in the NandoBeam product line, equipped with a new-generation power supply offering over 95% total output efficiency. This power feature enables the highly compact luminaire to use its lamps continuously at full power without any loss of performance. Ayrton has equipped the luminaire with a solid cluster of 55 lenses to help reduce its diameter. A double honeycomb system has been introduced to enhance contrast and eliminate stray reflections. The main benefit of the optical zoom system developed for the NandoBeam product line is constant efficiency regardless of the zoom aperture. One additional large advantage of the fixture is that NandoBeam is equipped with LumenRadio's wireless OEM RDM module as a standard feature.



## YVAN PÉARD

MANAGING DIRECTOR AT AYRTON

"We have introduced RDM in all our new products and quickly learned that RDM requires a level of technology, reliability, and performance that only LumenRadio's CRMX can provide. Their high-performance products with all the necessary RDM features, as well as engineering and on-site support, made the decision to make LumenRadio Ayrton's exclusive wireless DMX & RDM partner quite obvious".



The Lighting Company





## SGM G-Spot



SGM have a long history of delivering high quality innovative LED fixtures for the entertainment industry, with their latest being the G-Spot, the first IP65 moving head. As part of their continuous strive for improvement, SGM evaluated the available wireless products in early 2013 before settling on LumenRadio's CRMX technology for all wireless enabled SGM products going forward.

The G-Spot fixture is also based on SGM's revolutionary P-5 technology.

## ACME Cobra Spot

Featuring the latest lighting technology, state of the art craftsmanship, excellent optical system zooming from 9° to 61° and powerful light output, the Cobra Spot is a high performance luminaire, ideal for live shows, TV studios, theatres, large discotheques and all kinds of rental events. Cobra Spot is equipped with the smallest wireless DMX receiver in the world, CRMXchip, as standard.



## Innovative Dimmers RATPAC

Innovative Dimmers is the result of a rigging gaffer and an electrical engineer designing a dimmer that would be quiet enough to use on the set; it's called the RATPAC line. The idea caught on because all of their customers had the same need - to do the job faster and more efficiently. Unlike traditional dimmers, RATPACs are designed to be portable, versatile, and virtually silent. The combination of LumenRadio's powerful CRMX technology and the unique Whisper Fan Technology enables placement of the dimmers right on set, eliminating costly set up time and long cable runs.



# IMPLEMENTATION GUIDE

LumenRadio's award winning CRMX technology can with minimal effort be added to any fixture or device that might benefit from wireless DMX/RDM control. An extensive range of CRMX OEM products and accessories is available to accommodate a wide variety of indoor or outdoor products and applications. LumenRadio's OEM products are the smallest in the industry, including the CRMX-chip at just 6mm x 6mm, which greatly aids in many manufacturers' effort to make their equipment smaller and more compact.

Keep in mind that integration of wireless control technology is best done at an early stage of your product design process. Our extensive CRMX OEM Implementers Guide offers all the necessary information about dimensions, mounting, electrical interfaces, etc. that is required for the process. LumenRadio's engineering staff is also always available to assist you to achieve the optimal result with the least effort.

## The integration design process typically comprise the following steps:

- Select a CRMX OEM product; depending on your requirements this is a choice between DMX or DMX/RDM, a plug-in CRMX OEM classic module or a surface mounted CRMXchip/CRMX TiMo module
- Find a suitable location inside your product to mount the OEM module or redesign your PCB to carry the surface mounted component
- Provide mounting facilities if you are using a module; most commonly easy to use and inexpensive snap-in plastic stand-offs
- Provide the necessary electrical connections to the OEM product - either via the via the 20-pin connector for a CRMX OEM module, or directly to the chip for CRMXchip/CRMX TiMo
- Select an antenna; indoor or outdoor; straight or right angle, etc.
- Find a suitable location on your product where the antenna can be mounted
- Install the antenna cable between the module and antenna locations

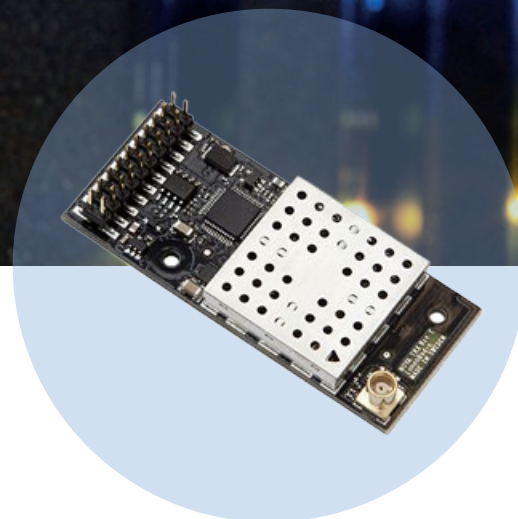

We can also provide design and development services for products and technologies related to lighting control systems. Our engineering staff has for a long time been active in the development and maintenance of new communication standards such as RDM E1.20 and RDMnet E1.33 and is exceptionally well versed in RDM controller development. It also has extensive expertise in the other protocols commonly used in entertainment and architectural lighting control, including the many Ethernet based protocols.

One example of such a product co-developed with an OEM is ROBE's RUNIT WTX™. This USB connected interface provides an RDM controller and wired and wireless DMX, RDM, and firmware upload capabilities to ROBE's entire line of products. Most of ROBE's fixtures are equipped with LumenRadio's CRMX technology as standard or as an optional feature.



ROBE RUNIT WTX™

# MANAGEMENT SOFTWARE

**SuperNova offers a complete system management tool for monitoring and configuring your lighting network. With support for both CRMX enabled transmitters and Art-Net nodes, SuperNova provides a clear and detailed view of the status of your entire network - both wired and wireless devices. RDM enabled fixtures can be displayed, monitored and configured from the software, with configuration of common tasks just a click away. SuperNova 3 was awarded the PLASA award for Innovation 2013.**

## HOW DO I MANAGE MY SYSTEM?

A computer running SuperNova can be connected into the show network and run as a monitor for the whole system. Each sensor and signal can be monitored - if a sensor goes outside of a range, it can

trigger an alert. Alerts can be configured as e-mails, push notifications or system logs - depending on preferences. By setting a relevant monitoring system, it is possible to reduce maintenance routines and proactively resolve problems in the rig before they become issues with the production.

## WHAT ABOUT NON-WIRELESS FIXTURES?

By default, SuperNova can communicate with all CRMX products with Ethernet connectivity. This enables monitoring of the wireless link and any RDM enabled devices connected to RDM compatible CRMX receivers. However, LumenRadio recognize that not all fixtures are connected wirelessly in typical systems and SuperNova also allows communication with Art-Net compliant devices from other manufacturers.

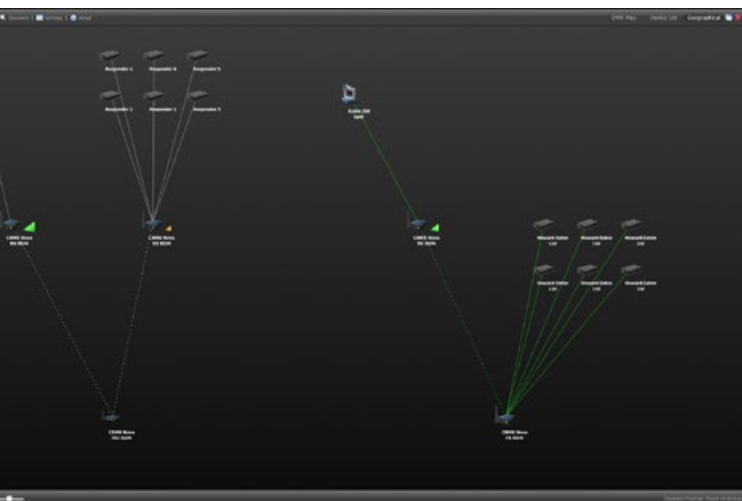

## SYSTEM MANAGEMENT

- Visualise and manage all your CRMX, RDM, and Art-Net compliant devices
- Color coded lines and icons indicate the health of the whole system.
- Solid lines indicate a wired connection while dotted lines indicate a wireless connection.
- Monitor wireless signal strength, DMX information and device sensors.
- Alarms and warnings can be sent out through e-mail, push notifications to smart phones or saved in an SQL database.



---

## REMOTE PATCHING

- Patching devices; simply drag and drop a device to where you want it and SuperNova will automatically patch the device.
- Display the DMX data for each channel to see what data is being sent out to a specific device.

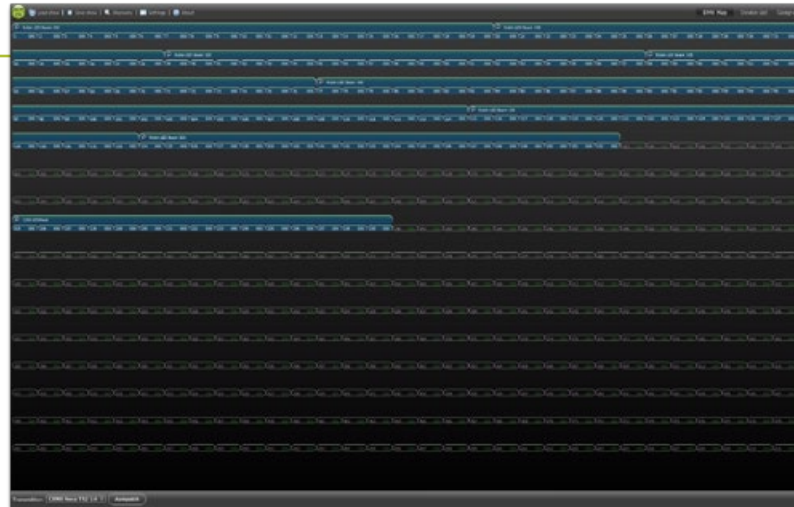

---

## FREQUENCY MANAGEMENT

- See what frequencies the CRMX system is using.
- Witness the automated frequency adaptation in real-time.
- View both your own traffic and the traffic of other surrounding wireless systems.
- Management of each individual transmitter's frequency usage.

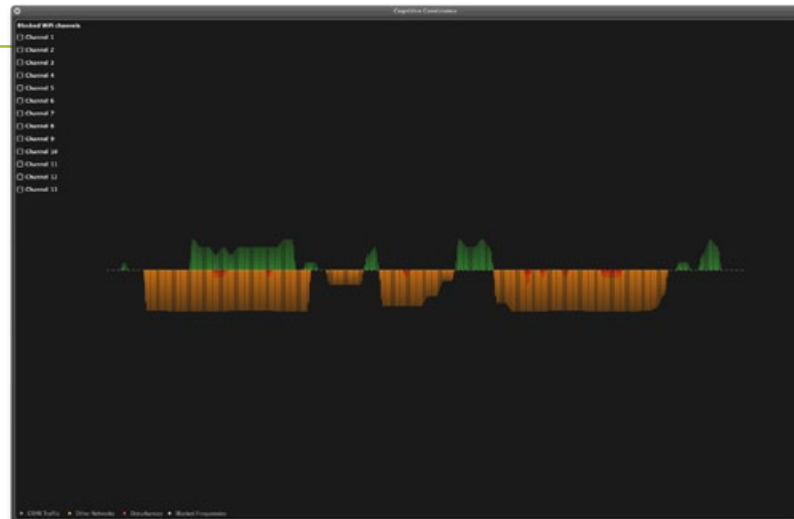

---

## VIRTUAL CONSOLE

- Local control of a single fixture's DMX channels.
- Automatic download of channel allocations from compatible RDM fixtures.
- Inject DMX data directly into fixtures for setup and testing.

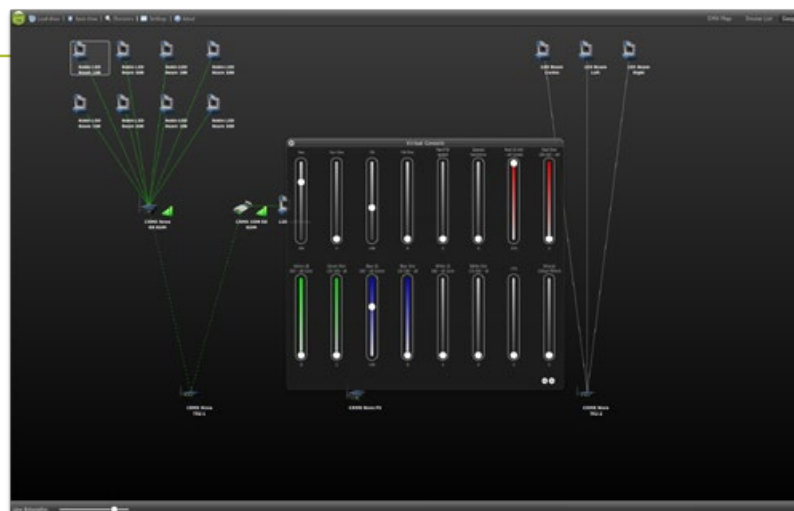

# ACCESSORIES

LumenRadio have a wide variety of different accessories. All CRMX Nova, Slim and Outdoor products ship with a standard 2 dBi antenna, but when you need more than that our range of high gain indoor and outdoor antennas makes sure any installation will be a success. A complete range of cables and adapters also ensure you can connect everything together.

## Adapters



### COAXIAL CABLE ADAPTER

N-female to RP-TNC male  
Order code: 800-9201



### COAXIAL CABLE ADAPTER

N-male to N-male  
Order code: 800-9204



### COAXIAL CABLE ADAPTER

N-female to N-female  
Order code: 800-9202



### XLR ADAPTER

5 pin male to 5 pin male  
Order code: 102-1010



### COAXIAL CABLE ADAPTER

N-female to RP-TNC female  
Order code: 800-9203

## Indoor antennas



**2 dBi OMNI ANTENNA**  
RP-TNC male connector  
Order code: 104-1001



**2 dBi OMNI ANTENNA**  
RP-SMA male connector  
Order code: 104-1006



**5 dBi OMNI ANTENNA**  
RP-TNC male connector  
Order code: 104-1003



**2 dBi OMNI OEM ANTENNA**  
R/A MCX connector  
**25 cm**  
Order code: 104-1008  
**35 cm**  
Order code: 104-1009



**POWER DIVIDER 2.4 GHZ**  
Order code: 104-2001

## Outdoor antennas



**2 dBi OMNI ANTENNA**  
N-male connector  
Order code: 104-1002



**6 dBi OMNI ANTENNA**  
N-female connector  
Order code: 104-1004



**2 dBi BLACK 90° ANGLED ANTENNA**  
N-male connector  
Order code: 104-1010



**12 dBi DIRECTIONAL ANTENNA**  
N-female connector  
Order code: 104-1012

## Cables



**FLEXIBLE LOW LOSS CABLE**  
N-male to N-male  
**1 meter**  
Order code: 800-9001  
**3 meters**  
Order code: 800-9002  
**5 meters**  
Order code: 800-9003



**SUPER LOW LOSS CABLE**  
N-male to N-male  
**1 meter**  
Order code: 800-9101  
**3 meters**  
Order code: 800-9102  
**5 meters**  
Order code: 800-9103  
**10 meters**  
Order code: 800-9104



**OEM COAX CABLE**  
Indoor  
R/A MCX to RP-TNC female  
**15 cm**  
Order code: 102-2001  
**25 cm**  
Order code: 102-2003



**OEM COAX CABLE**  
Outdoor  
R/A MCX to N female  
**15 cm**  
Order code: 102-2002  
**25 cm**  
Order code: 102-2005



**OEM COAX CABLE**  
CRMX TiMo  
IPEX to RP-TNC female  
**15 cm**  
Order code: 102-2006  
**25 cm**  
Order code: 102-2007



**CRMX UPGRADE CABLE**  
Order code: 102-4001

# OUR DISTRIBUTORS

## Asia

### CHINA



**Leafun Light & Sound Technology Co., Ltd.**

Phone: +86 20 855 29280

Fax: +86 20 855 29159

Email: sales@leifull.com

Web: www.leifull.com

### SINGAPORE, MALAYSIA & INDONESIA



**Total Solution Marketing Pte Ltd**

Phone: +65 62879878

Fax: +65 62879388

Email: sales@tsm-int.com

Web: www.tsm-int.com

### JAPAN



**Mileruntech.co.Ltd**

Phone: +81 35496 9836

Fax: +81 35496 9839

Email: usami@mileruntech.com

Web: www.mileruntech.com

### INDIA



**Integrated Entertainment Solutions**

Phone: +91 22 23018804

Fax: +91 22 23018805

Email: iesolns@gmail.com

Web: www.iesolns.com

### SOUTH KOREA



**ArtTech Lighting**

Phone: +822 961 5311

Fax: +822 961 5314

Email: arttechlight@korea.com

Web: www.arttechlighting.com

## Middle East

### UNITED ARAB EMIRATES



**Oasis Enterprises LLC**

Phone: +9714 2821337

Fax: +9714 2822617

Email: karim.abboud@oasisppd.com

Web: www.oasisppd.com



**ROBE Middle East Trading LLC**

Phone: +971 4 885 3223

Email: info@robe-me.com

Web: www.robe.cz

## Americas & Oceania

### USA & CANADA



**A.C. Lighting Inc.**

Phone: +1 4162559494

Fax: +1 4162553514

Email: northamerica@aclighting.com

Web: www.aclighting.com

### ARGENTINA



**TSD Group**

Phone: +54 11 4116 3790

Fax: +54 11 4116 3790

Email: tsd@tsd.com.ar

Web: www.tsd.com.ar

### BRAZIL



**NewArt Iluminacao LTDA**

Phone: +55 (11) 3641-5103

Email: info@robebrasil.com.br

Web: www.robebrasil.com.br

### AUSTRALIA



**ULA Group**

Phone: +61 7 5509 4633

Fax: +61 7 5509 4677

Email: info@ulagroup.com

Web: www.ulagroup.com

### NEW ZEALAND



**Kenderdine Electrical Ltd**

Phone: +64 9 302 4100

Fax: +64 9 302 4102

Email: sales@kelpls.co.nz

Web: www.kelpls.co.nz/

## Africa

### SOUTH AFRICA



**DWR Distribution**

Phone: +27 11 793 5066

Fax: +27 11 792 5076

Email: sales@dwrdistribution.co.za

Web: www.dwrdistribution.co.za

# Europe

## AZERBAIJAN



**BISCHOFF GROUP, LLC**  
Phone: +994 50 206 20 48  
Fax: +994 12 564 56 85  
Email: info@bischoff.az  
Web: www.bischoff.az

## BELGIUM & LUXEMBOURG



**Audio Visual Lighting bvba**  
Phone: +32 52 412924  
Fax: +32 52 412530  
Email: luc@avl.be  
Web: www.avl.be



**Controllux B.V.B.A.**  
Phone: +32 13 480 600  
Fax: +32 13 480 609  
Email: info@controllux.be  
Web: www.controllux.be

## BOSNIA, SERBIA, MONTENEGRO & MACEDONIA



**Svetlost Teatar**  
Phone: +381 11 3977 570  
Fax: +381 11 3978 014  
Email: office@steatar.rs  
Web: www.steatar.rs

## CYPRUS



**ArchilX**  
Phone: +357 2525 2484  
Email: ben@archilx.com

## CZECH REPUBLIC



**ROBE lighting s. r. o.**  
Phone: +420 602 883 994  
Fax: +420 571 751515  
Email: petr.kolmacka@robe.cz  
Web: www.robe.cz

## DENMARK & GREENLAND



**Gobo & Highlight A/S**  
Phone: +45 7020 1966  
Fax: +45 7020 1967  
Email: gobo@gobo.dk  
Web: www.gobo.dk

## ESTONIA



**E&T Ltd**  
Phone: +372 6552721  
Fax: +372 6552710  
Email: valgus@valgus.ee  
Web: www.valgus.ee

## FINLAND



**Sun Effects Oy**  
Phone: +358 45 113 0005  
Email: riku.sourama@suneffects.fi  
Web: www.suneffects.fi

## FRANCE



**Avab Transtechnik France**  
Phone: +33 1 42 43 35 35  
Fax: +33 1 42 43 08 05  
Email: info@avab.fr  
Web: www.avab.fr

## GERMANY



**LMP Lichttechnik Vertriebs GmbH**  
Phone: +49 (0) 5451 5900 800  
Fax: +49 (0) 5451 5900 59  
Email: sales@lmp.de  
Web: www.lmp.de

## HUNGARY



**PRO Világítástechnika**  
Phone: +36-30-218-4044  
Email: hg@provilagitas.hu  
Web: www.provilagitas.hu

## ISRAEL



**Danor Theatre and Studio Systems Ltd**  
Phone: +972 9 7444222  
Fax: +972 9 7466466  
Email: erez@danor.com  
Web: www.danor.com

## ITALY



**RM Multimedia srl**  
Phone: +39 0541 833103  
Fax: +39 0541 833103  
Email: info@rmmultimedia.it  
Web: www.rmmultimedia.it

## LATVIA



**NA Company**  
Phone: +37167801111  
Fax: +37167556505  
Email: janiss@na.lv  
Web: www.na.lv

## NETHERLANDS



**Rolight**  
Phone: +31 53 432 06 44  
Fax: +31 53 430 12 01  
Email: info@rolight.nl  
Web: www.rolight.nl

## NORWAY & SVALBARD



**Stagelab**  
Phone: +47 22 98 22 22  
Fax: +47 22 98 22 23  
Email: post@stagelab.no  
Web: www.stagelab.no

## POLAND



**LTT sp. z o.o.**  
Phone: +48 228450065  
Fax: +48 228450069  
Email: ltt@ltd.com.pl  
Web: www.ltd.com.pl

## PORTUGAL



**NAN Audiovisuais**  
Phone: +351 256 579 650  
Fax: +351 256 579 659  
Email: info@nan.pt  
Web: www.nan.pt

## ROMANIA



**Symph Electronics**  
Phone: +40 749 335 906  
Email: office@symphelectronics.ro  
Web: www.symphelectronics.ro

## RUSSIA



**SofitLight**  
Phone: +7 495 925 32 08  
Email: info@sofitlight.ru  
Web: www.sofitlight.ru

## SLOVAKIA



**ROBE lighting s. r. o.**  
Phone: +420 602 883 994  
Fax: +420 571 751515  
Email: petr.kolmacka@robe.cz  
Web: www.robe.cz

## SLOVENIA



**MK Light Sound d.o.o.**  
Phone: +386 1 89 63 112  
Fax: +386 1 89 63 110  
Email: info@mklight-sound.si  
Web: www.mklight-sound.si

## SPAIN



**Stonex Show Lighting s.l.**  
Phone: +34 91 428 1050  
Email: stonex@stonexsl.com  
Web: www.stonexsl.com

## SWEDEN



**BigBlack by BellaLite**  
Phone: +46 10-47 00 220  
Fax: +46 10-47 00 265  
Email: kundtjanst@bigblack.se  
Web: www.bigblack.se

## SWITZERLAND



**IQunlimited GmbH**  
Phone: +41 44 380 17 52  
Fax: +41 44 380 17 55  
Email: info@iqunlimited.biz  
Web: www.iqunlimited.biz

## TURKEY



**Atempo Ses ve Işık Sistemleri Ltd. Şti**  
Phone: +90 (212) 288 06 12  
Fax: +90 (212) 267 34 48  
Email: info@atempo.com.tr  
Web: www.atempo.com.tr

## UK & IRELAND



**A.C. Entertainment Technologies Ltd.**  
Phone: +44 (0) 1494 446 000  
Fax: +44 (0) 1494 461024  
Email: sales@ac-et.com  
Web: www.ac-et.com

For countries and territories not listed, contact LumenRadio sales directly at sales@lumenradio.com or +46 31 301 03 70.

# CRMX Nova specifications

www.lumenradio.com/nova

	CRMX Nova FX RDM (Flex reconfigurable)	CRMX Nova TX2 RDM (RDM transmitter)	CRMX Nova RX RDM (RDM receiver)	CRMX Nova TX (DMX transmitter)	CRMX Nova RX (DMX receiver)
Model code (Order code)	IN-RFX1 (800-3001)	IN-RTX2 (800-2101)	IN-RRX1 (800-2001)	IN-DTX1 (800-1101)	IN-DRX1 (800-1001)
Supported protocols					
USITT DMX-512 (1986 & 1990) and DMX512-A	Yes	Yes	Yes	Yes	Yes
Art-Net 1, II & 3, ETCNet 2 & 3, Strand ShowNet, Streaming ACN, Pathport, KiNet V1 & V2	Yes, input any protocol and output any protocol	Yes, input any protocol	No	No	No
RDM ANSI E1.20	Yes	Yes	Yes	No	No
Works with CRMX SuperNova RDM Controller	Yes	Yes	Yes	No	No
Firmware upgrade	Ethernet	Ethernet	XLR	XLR	XLR
DMX interface					
Number of universes supported	1	2	1	1	1
Full DMX fidelity and frame integrity	Yes	Yes	Yes	Yes	Yes
Error correction and packet recovery	Yes	Yes	Yes	Yes	Yes
Frame synchronization	Less than 0.01 ms	Less than 0.01 ms	Less than 0.01 ms	Less than 0.01 ms	Less than 0.01 ms
End-to-end DMX latency	Less than 5 ms	Less than 5 ms	Less than 5 ms	Less than 5 ms	Less than 5 ms
Auto sensing of DMX frame rate and size	Yes	Yes	Yes	Yes	Yes
Supported DMX frame rates	0.8 - 7352 Hz Transmitter mode / 1 - 830 Hz <sup>1</sup> Receiver mode	0.8 - 7352 Hz	1 - 830 Hz <sup>1</sup>	0.8 - 7352 Hz	1 - 830 Hz <sup>1</sup>
Number of DMX channels supported	0 - 512	0 - 1024	0 - 512	0 - 512	0 - 512
Loss of DMX input behavior	DMX output will go into high impedance state	Timeout after 1.25 s	DMX driver will go into high impedance state	Timeout after 1.25 s	DMX driver will go into high impedance state
ESD protected interfaces	Yes	Yes	Yes	Yes	Yes
W-DMX™ G2/G3/G4/G4S Compatibility <sup>2</sup>	Yes, in receive mode	No	Yes	No	Yes
Power					
High voltage input	100-240VAC / 47-70Hz / 0.12A / 10W	100-240VAC / 47-70Hz / 0.25A / 22W	100-240VAC / 47-70Hz / 0.12A / 10W	100-240VAC / 47-70Hz / 0.12A / 10W	100-240VAC / 47-70Hz / 0.12A / 10W
Low voltage input	12VDC ±20% / 0.6A / 7.5W	12VDC ±20% / 1A / 12W	12VDC ±20% / 0.2A / 2.5W	12VDC ±20% / 0.3A / 4W	12VDC ±20% / 0.2A / 2.5W
Power over Ethernet	Yes	Yes	No	No	No
Transient protected power inputs	Yes	Yes	Yes	Yes	Yes
RF characteristics					
Modes of operation	Transmitter, Receiver	Transmitter	Receiver	Transmitter	Receiver
Automated Cognitive Coexistence	Yes	Yes	Yes	Yes	Yes
Dynamic adaptive frequency hopping	Yes	Yes	Yes	Yes	Yes
Recoverable Radio Packet Error Rate	30%	30%	30%	30%	30%
Operational frequency range	2402-2480 MHz	2402-2480 MHz	2402-2480 MHz	2402-2480 MHz	2402-2480 MHz
RF output in high power mode	300 mW (25 dBm) <sup>3</sup>	300 mW (25 dBm) <sup>3</sup>	300 mW (25 dBm) <sup>3</sup>	300 mW (25 dBm) <sup>3</sup>	N/A
RF output in normal power mode	100 mW (20 dBm)	100 mW (20 dBm)	100 mW (20 dBm)	100 mW (20 dBm)	N/A
RF output in low power mode	35 mW (15 dBm) or 10 mW (10 dBm)	35 mW (15 dBm) or 10 mW (10 dBm)	35 mW (15 dBm) or 10 mW (10 dBm)	35 mW (15 dBm) or 10 mW (10 dBm)	N/A
RF modulation	GFSK	GFSK	GFSK	GFSK	GFSK
Sensitivity at 0.1% Packet Error Rate	-96 dBm	-96 dBm	-96 dBm	-96 dBm	-96 dBm
Tested link range (High power mode using standard antennas in free line-of-sight)	Up to 1000 m	Up to 1000 m	Up to 1000 m	Up to 1000 m	Up to 1000 m
Recovery time upon loss of radio link	Less than 1 s	N/A	Less than 1 s	N/A	Less than 1 s
Approvals					
FCC: 15.247&68 Class B; Canada ICES 003 CE; EN 301 489-1; EN 301 489-3; EN 300 328; SS-EN 61547-2009; EN 60 950; SRRC - China; ARIB STD-T66 - Japan	Yes	Yes	Yes	Yes	Yes
Environment					
Operating temperature range (ambient)	-20° C to +50° C -4° F to 122° F	-20° C to +50° C -4° F to 122° F	-20° C to +50° C -4° F to 122° F	-20° C to +50° C -4° F to 122° F	-20° C to +50° C -4° F to 122° F
Humidity	0-90% non-condensing	0-90% non-condensing	0-90% non-condensing	0-90% non-condensing	0-90% non-condensing
Physical					
Enclosure	Anodized extruded aluminum	Anodized extruded aluminum	Anodized extruded aluminum	Anodized extruded aluminum	Anodized extruded aluminum
Dimensions (W x H x D) excluding antenna	110 x 44 x 160 mm 4.3" x 1.7" x 6.3"	220 x 44 x 125 mm 8.6" x 1.7" x 4.9"	110 x 44 x 160 mm 4.3" x 1.7" x 6.3"	110 x 44 x 160 mm 4.3" x 1.7" x 6.3"	110 x 44 x 160 mm 4.3" x 1.7" x 6.3"
Weight	0.8 kg, 1.8 lbs	0.9 kg, 2.0 lbs	0.7 kg, 1.5 lbs	0.7 kg, 1.5 lbs	0.7 kg, 1.5 lbs
Connectors					
Antenna connector	RP-TNC female	RP-TNC female	RP-TNC female	RP-TNC female	RP-TNC female
DMX connectors	1 XLR 5-pin female	2 XLR 5-pin male	1 XLR 5-pin female	1 XLR 5-pin male	1 XLR 5-pin female
Ethernet connectors	1 RJ45	1 Neutrik® Ethercon™ RJ45			
DC input	Pluggable terminal strip, Phoenix® MSTB 2.5	Pluggable terminal strip, Phoenix® MSTB 2.5	Pluggable terminal strip, Phoenix® MSTB 2.5	Pluggable terminal strip, Phoenix® MSTB 2.5	Pluggable terminal strip, Phoenix® MSTB 2.5
AC input	IEC 320-C14 Male	IEC 320-C14 Male	IEC 320-C14 Male	IEC 320-C14 Male	IEC 320-C14 Male
Supplied accessories	AC power cord, DC power connector, 2 dBi RP-TNC antenna	AC power cord, DC power connector, 2 dBi RP-TNC antennas	AC power cord, DC power connector, 2 dBi RP-TNC antenna	AC power cord, DC power connector, 2 dBi RP-TNC antenna	AC power cord, DC power connector, 2 dBi RP-TNC antenna



<sup>1</sup> Limited by the DMX512-A standard    <sup>2</sup> Compatible with W-DMX™ transmitters on the 2.4 GHz band    <sup>3</sup> Allowed in North America only

All CRMX products are covered by the United States Patent No. 7,432,803. CRMX technology is patent pending.

*"I was most impressed by its ease of use. The SuperNova software provides an ideal interface to set up the devices and monitor them during use"*

# Light Fantastic

Photo: Mark Rainford

**A.C. Entertainment Technologies Ltd.'s Lighting division has supplied a range of LumenRadio products to Lighting, Sound, Staging and AV specialists Black Light, based in Edinburgh, to create a wireless DMX connection for lighting up the city's Melville Monument as part of the recent International Science Festival.**

The event, called 'Light Fantastic', took place 'from sunset to sunrise' between 12th March to 28th April 2015. It invited visitors to 'Change the face of the Edinburgh skyline with a Tweet!' Organisers encouraged the public to Tweet their favourite colours using the hashtag #lightfantastic, which would then change the lighting state at the Melville Monument automatically. Black Light invested in a LumenRadio CRMX Nova TX2 RDM transmitter, four CRMX Nova transmitters and four outdoor-rated receivers, plus ancillary antennae and cables which were utilized on this event.

"Phil Haldane from Black Light created custom script allowing the software to poll the amount of Tweets every 3 minutes. The most popular colour Tweeted would then automatically change the lighting onto the monument", explains Andrew Green, who was responsible for the Wireless DMX and ArtNet systems. "The LumenRadio products were used to create a wireless DMX link between the control room in the centre of the monument, and the fixtures on the outside perimeter of St. Andrew Square."

"When choosing which wireless system to invest in we did a lot of research as our main concerns were reliability, range and functionality. As we were using the system in a heavy Wi-Fi traffic area in Edinburgh's city centre, it was imperative that the system was reliable, not prone to interference, and did not disturb other networks. LumenRadio's coexistence function was ideal for this, as well as its high range and durability."

Operating licence-free on the 2.4GHz frequency, LumenRadio's patented Cognitive Coexistence technology ensures optimum performance even when other wireless systems are operating in the same area. LumenRadio's innovative CRMX technology continuously scans the wireless frequencies, detecting activity from other networks and where gaps are available. The radio modules 'hop' into these available frequencies, making best use of the available space whilst reducing the effects on other networks.

"I was most impressed by its ease of use. The SuperNova software provides an ideal interface to set up the devices and monitor them during use, whilst the capability to monitor RDM devices and Wi-Fi traffic in the area is also extremely useful", Andrew continues. "I configured the system at Black Light's offices, and once onsite it worked first time, and for a further six weeks without fail, whilst enduring some typical Scottish weather - including high winds, rain, snow, and even sun!"

# CRMX Slim specifications

www.lumenradio.com/slim

	CRMX Slim TX	CRMX Slim RX RDM
Model code (Order code)	OS-DTX1 (800-5101)	OS-RRX1 (800-5001)
Supported protocols		
USITT DMX-512 (1986 & 1990) and DMX512-A	Yes	Yes
RDM ANSI E1.20	No	Yes
Firmware upgrade	TIA/EIA-485	TIA/EIA-485
DALI (converted from DMX)	No	Yes, broadcast/16 groups/ 64 short addresses
Works with CRMX SuperNova RDM controller	No	Yes
<b>DMX interface</b>		
Number of universes supported	1	1
Full DMX fidelity and frame integrity	Yes	Yes
Error correction and packet recovery	Yes	Yes
Frame synchronization	Less than 0.01 ms	Less than 0.01 ms
End-to-end DMX latency	Less than 5 ms	Less than 5 ms
Auto sensing of DMX frame rate and frame size	Yes	Yes
Supported DMX frame rates	0,8 - 7352 Hz	1 - 830 Hz <sup>1</sup>
Number of DMX channels supported	0 - 512	0 - 512
Loss of DMX input behavior	Timeout after 1.25 s	DMX driver output will go into high impedance state
W-DMX™ G2/G3/G4/G4S Compatibility <sup>2</sup>	No	Yes
<b>Power</b>		
High voltage input	100-240VAC / 47-70Hz / 0.12A / 10W	100-240VAC / 47-70Hz / 0.12A / 10W
Transient protected power input	Yes	Yes
<b>RF characteristics</b>		
Modes of operation	Transmitter	Receiver
Automated Cognitive Coexistence	Yes	Yes
Dynamic adaptive frequency hopping	Yes	Yes
Recoverable Radio Packet Error Rate	30%	30%
Operational frequency range	2402-2480 MHz	2402-2480 MHz
RF output in high power mode	300 mW (25 dBm) <sup>3</sup>	300 mW (25 dBm) <sup>3</sup>
RF output in normal power mode	100 mW (20 dBm)	100 mW (20 dBm)
RF output in low power mode	35 mW (15dBm) or 10 mW (10 dBm)	35 mW (15 dBm) or 10 mW (10 dBm)
RF modulation	GFSK	GFSK
Sensitivity at 0.1% Packet Error Rate	-96 dBm	-96 dBm
Tested link range (High power mode using standard antennas in free line-of-sight)	Up to 1000 m	Up to 1000 m
Recovery time upon loss of radio link	N/A	Less than 1 s
<b>Approvals</b>		
FCC: 15.247&68 Class B; Canada ICES 003 CE; EN 301 489-1; EN 301 489-3; EN 300 328; SS-EN 61547:2009; EN 60 950; SRRC - China; ARIB STD-T66 - Japan	Yes	Yes
<b>Environment</b>		
Operating temperature range (ambient)	-20° C to +50° C -4° F to 122° F	-20° C to +50° C -4° F to 122° F
Humidity	Water jets protected	Water jets protected
<b>Physical</b>		
Enclosure	IP65 PC Plastic	IP65 PC Plastic
Dimensions (W x H x D) excluding antenna	90 x 174 x 40 mm 3.5" x 6.8" x 1.6"	90 x 174 x 40 mm 3.5" x 6.8" x 1.6"
Weight	0.25 kg, 0.5 lbs	0.25 kg, 0.5 lbs
<b>Connectors</b>		
Antenna connector	N female	N female
DMX connector	Screwless terminal 0.08-0.5 mm <sup>2</sup> / 20-28AWG	Screwless terminal 0.08-0.5 mm <sup>2</sup> / 20-28AWG
DALI connector	Screwless pluggable terminal 0.5-1.3 mm <sup>2</sup> / 16-28AWG	Screwless pluggable terminal 0.5-1.3 mm <sup>2</sup> / 16-28AWG
AC input	Screwless pluggable terminal 0.5-1.3 mm <sup>2</sup> / 16-28AWG	Screwless pluggable terminal 0.5-1.3 mm <sup>2</sup> / 16-28AWG
Supplied accessories	2 dBi N antenna	2 dBi N antenna

<sup>1</sup> Limited by the DMX512-A standard

<sup>2</sup> Compatible with W-DMX™ transmitters on the 2.4 GHz band

<sup>3</sup> Allowed in North America only

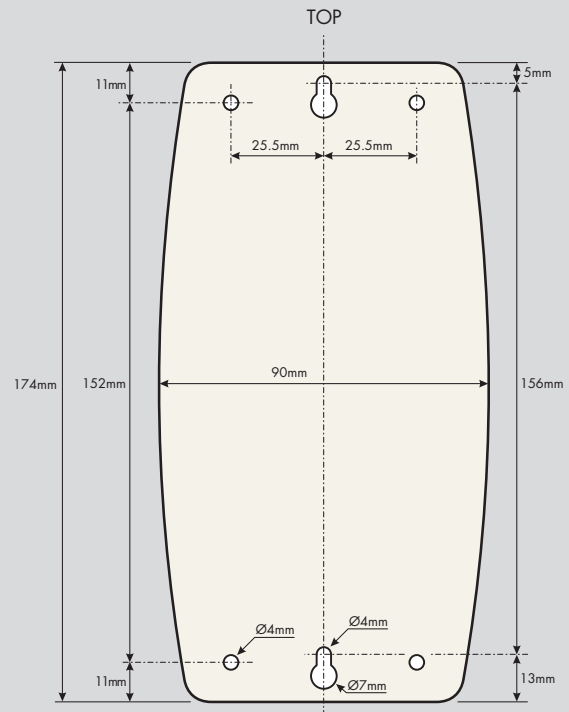
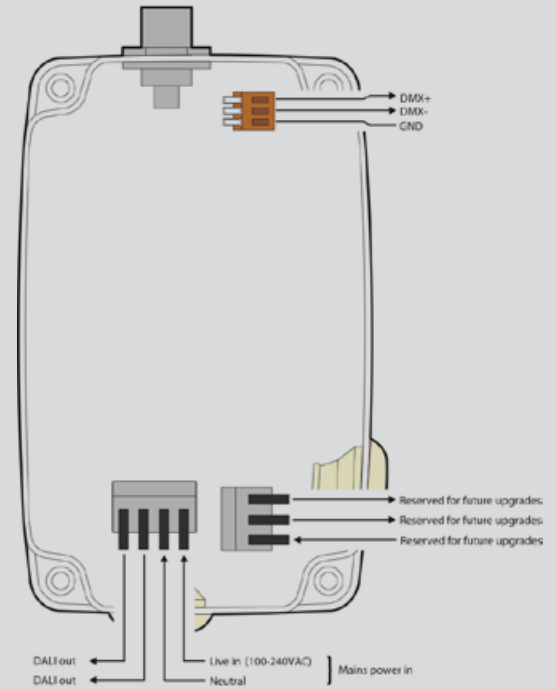

All CRMX products are covered by the United States Patent No. 7,432,803. CRMX technology is patent pending.



# Melbourne Airport

***“The sheer scale of the site, access issues and the number of control channels needed (over 40,000) meant that we had to use every tool in the box”***

*Nicolas Moreau, ENTTEC founder and General Manager.*

**Melbourne Airport welcomes over 30 million travellers each year, with that number set to grow over the next few years. A team of visionaries at APAM (Australia Pacific Airports Melbourne) decided that these travellers, and those who come to greet them, deserved a better experience**

LumenRadio’s long-term OEM partner, ENTTEC together with Mint Lighting Design, was brought on-board to provide custom lighting solution to realize the vision and design proposed for Melbourne Airport.

Mint Lighting Design and ENTTEC transformed the forecourt and main terminal facade with a dynamic lighting installation. The project

has 12 individual sites programmed as one to create an intricate, synchronized light show with more than 40,000 pixels requiring 57 universes of control. The project involved more than 2,140 individual components.

In order to distribute DMX data to the difficult locations of the site, ENTTEC custom made a wireless DMX system to suit the site-specific requirements. The wireless system contains of one transmitter and nine receivers, all based on LumenRadio’s CRMX OEM modules. Due to the extreme flexibility of the LumenRadio OEM solution the team at ENTTEC were able to create these custom solutions very quickly to fit the project time-line.

# CRMX Outdoor specifications

www.lumenradio.com/outdoor

	CRMX Outdoor Flex	CRMX Outdoor Receiver
Model code (Order code)	ON-RFX1 (800-4101)	ON-RRX1 (800-4001)
<b>Supported protocols</b>		
USITT DMX-512 (1986 & 1990) and DMX512-A	Yes	Yes
Art-Net 1, II & 3, ETCNet 2 & 3, Strand ShowNet, Streaming ACN, Pathport, KiNet V1 & V2	Yes, input any protocol and output any protocol	No
RDM ANSI E1.20	Yes	Yes
Firmware upgrade	Ethernet	TIA/EIA-485
Works with CRMX SuperNova RDM controller	Yes	Yes
<b>DMX interface</b>		
Number of universes supported	1	1
Full DMX fidelity and frame integrity	Yes <sup>1</sup>	Yes
Error correction and packet recovery	Yes	Yes
Frame synchronization	Less than 0.01 ms	Less than 0.01 ms
End-to-end DMX latency	Less than 5 ms <sup>2</sup>	Less than 5 ms
Auto sensing of DMX frame rate and frame size	Yes	Yes
Supported DMX frame rates	1 - 830 Hz <sup>3</sup> / 0.8 - 7352 Hz	1 - 830 Hz <sup>3</sup>
Number of DMX channels supported	0 - 512	0 - 512
Loss of DMX input behavior	DMX driver output will go into high impedance state in receiving and repeating mode. Timeout after 1.25s in transmitting mode	DMX driver output will go into high impedance state
W-DMX™ G2/G3/G4/G4S Compatibility <sup>4</sup>	Yes, in receive mode	Yes
<b>Power</b>		
High voltage input	100-240VAC / 47-70Hz / 0.12A / 10W	100-240VAC / 47-70Hz / 0.12A / 10W
Transient protected power input	Yes	Yes
<b>RF characteristics</b>		
Modes of operation	Transmitter, Receiver and Repeater	Receiver
Automated Cognitive Coexistence	Yes	Yes
Dynamic adaptive frequency hopping	Yes	Yes
Recoverable Radio Packet Error Rate	30%	30%
Operational frequency range	2402-2480 MHz	2402-2480 MHz
RF output in high power mode	300 mW (25 dBm) <sup>5</sup>	300 mW (25 dBm) <sup>5</sup>
RF output in normal power mode	100 mW (20 dBm)	100 mW (20 dBm)
RF output in low power mode	35 mW (15 dBm) or 10 mW (10 dBm)	35 mW (15 dBm) or 10 mW (10 dBm)
RF modulation	GFSK	GFSK
Sensitivity at 0.1% Packet Error Rate	-96 dBm	-96 dBm
Tested link range (High power mode using standard antennas in free line-of-sight)	Up to 1000 m	Up to 1000 m
Recovery time upon loss of radio link	Less than 1 s	Less than 1 s
<b>Approvals</b>		
FCC: 15.247&68 Class B; Canada ICES 003 CE: EN 301 489-1; EN 301 489-3; EN 300 328; SS-EN 61547:2009; EN 60 950; SRRC - China; ARIB STD-T66 - Japan	Yes	Yes
<b>Environment</b>		
Operating temperature range (ambient)	-20° C to +50° C -4° F to 122° F	-20° C to +50° C -4° F to 122° F
Humidity	Ingression protection, submerged down to 1 m	Ingression protection, submerged down to 1 m
<b>Physical</b>		
Enclosure	IP67 Vandal proof housing	IP67 Vandal proof housing
Dimensions (W x H x D) excluding antenna	201 x 244 x 78 mm 7.9" x 9.6" x 3"	201 x 244 x 78 mm 7.9" x 9.6" x 3"
Weight	1.6 kg, 3.5 lbs	1.6 kg, 3.5 lbs
<b>Connectors</b>		
Antenna connector	N female	N female
DMX connector	Pluggable terminal strip, Phoenix® MSTB 2.5	Pluggable terminal strip, Phoenix® MSTB 2.5
DALI connector	Pluggable terminal strip, Phoenix® MSTB 2.5	Pluggable terminal strip, Phoenix® MSTB 2.5
AC input	13AWG Pluggable terminal strip	13AWG Pluggable terminal strip
Supplied accessories	2 dBi N antenna	2 dBi N antenna

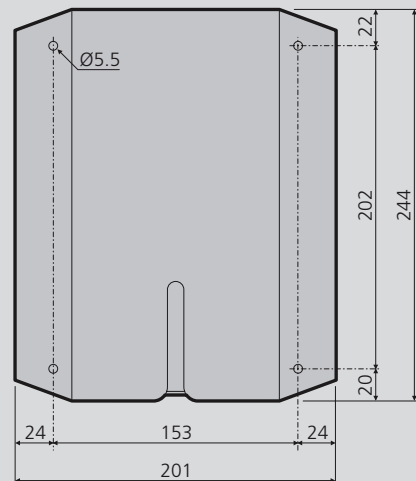
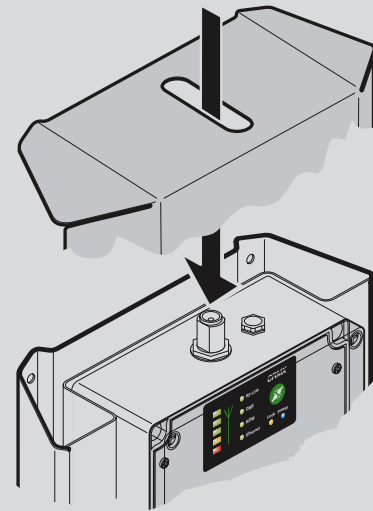
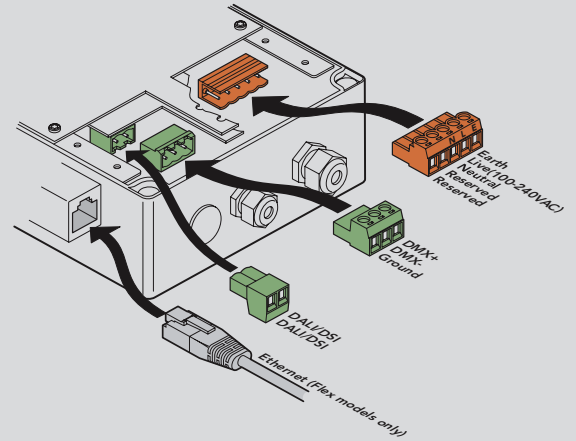

<sup>1</sup> Not in repeater mode  
<sup>2</sup> Latency increased with repeater  
<sup>3</sup> Limited by the DMX512-A standard  
<sup>4</sup> Compatible with W-DMX™ transmitters on the 2.4 GHz band  
<sup>5</sup> Allowed in North America only





**LumenRadio maintain headquarters and production in Gothenburg and development labs at Uddevalla Science Park, Sweden.**

**MAIN OFFICE**

LumenRadio AB  
Svangatan 2B  
SE-416 68 Gothenburg  
Sweden

Phone: +46 (0) 31 301 03 70

**SALES**

[sales@lumenradio.com](mailto:sales@lumenradio.com)

**MARKETING**

[marketing@lumenradio.com](mailto:marketing@lumenradio.com)

**SUPPORT**

[support@lumenradio.com](mailto:support@lumenradio.com)



*For daily updates, follow us on*  
**Facebook** ([facebook.com/lumenrf](https://facebook.com/lumenrf))  
**Twitter** ([twitter.com/lumenradio](https://twitter.com/lumenradio))  
**LinkedIn** ([linkedin.com/company/lumenradio-ab](https://linkedin.com/company/lumenradio-ab))

